

User Notes

150K-W (P/N 7Z07152)

OPHIR POWER METER

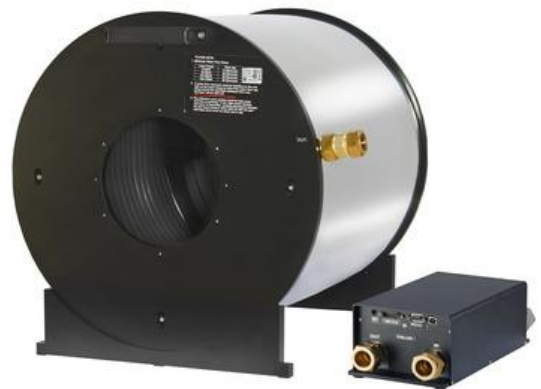

The 150K-W is designed to measure a 150kW laser with an approximately Gaussian beam and fiber output. It is carefully designed to withstand the high powers and power densities of the beam but to do so, the beam size, profile and orientation have to be as the power meter was designed for.

Section 1: Principle of Operation

The 150K-W consists of two units, the beam dump that absorbs the laser power and the measurement unit that measures the power absorbed by the beam dump.

1.1 Beam Dump:

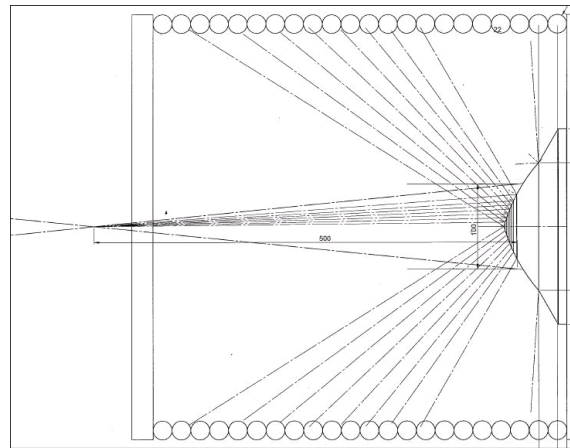
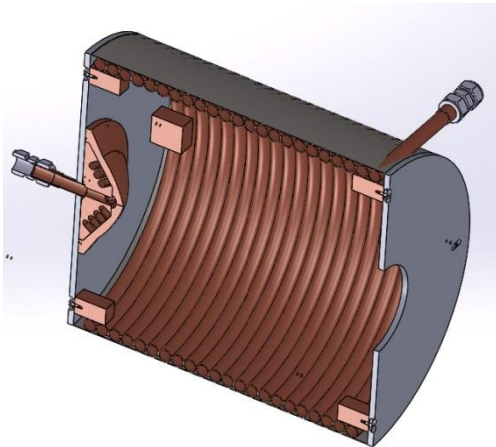

The beam falls on the water cooled reflecting cone which reflects about 97% of the incident light. The cone deflects and spreads out the beam to the cylindrical cooling coils as shown above. The cooling coils are coated with a black absorbing coating that absorbs ~85% of the beam. Most of the 15% that is scattered back is absorbed on the second or third bounce. The amount of radiation escaping from the beam dump at 150kW is calculated to be less than 600W. In order for the beam dump to work properly and prevent too high of a concentration of power on the critical surfaces, the beam must fulfill the following conditions:

- Beam Profile: The beam shape should be approximately Gaussian or flattened Gaussian with beam intensity in the center less than a Gaussian beam.
- Beam divergence and Size. $1/e^2$ beam diameter (86% of the beam intensity) should be 100mm at the point where the beam falls on the reflecting cone. The beam can be anywhere from parallel to diverging at 6 degrees angle.
- The beam should be centered on the cone to within ± 5 mm and perpendicular to the axis of the cone to within ± 2 deg. This is to ensure that the reflected beam will all be absorbed by the cooling coils.
- The reflecting cone must be kept clean and free from dust since the high power density can burn dust particles or other impurities into the surface.

1.2 Measuring Unit:

The measuring unit consists of a water flow meter and two water temperature sensors with associated electronics in an appropriate casing. Below is a cutaway view of the measuring unit showing the main parts. The measuring unit has highly accurate measuring components so the expected accuracy of measurement is high.

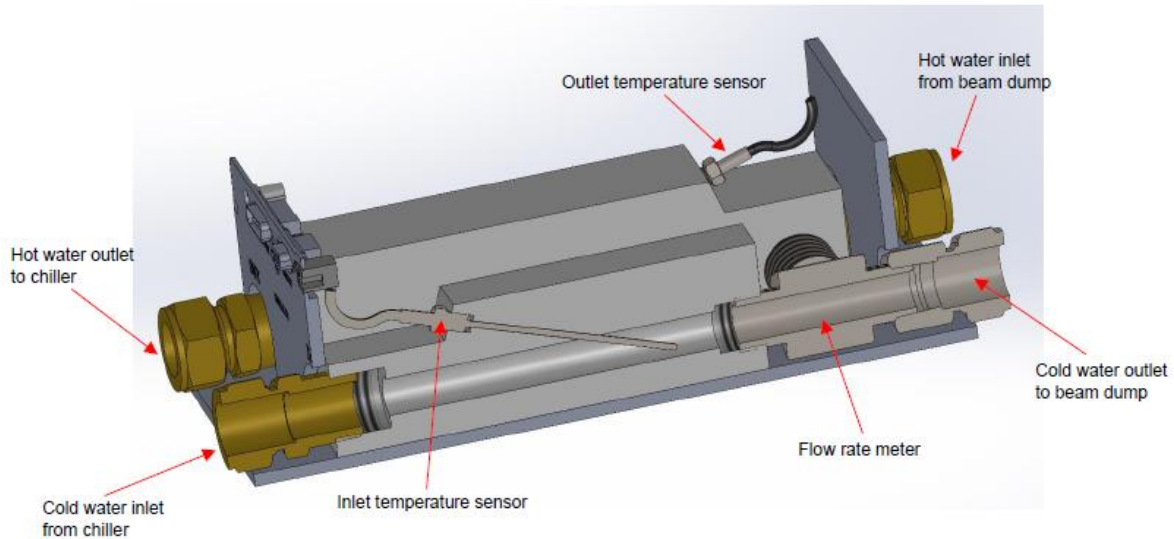

Below is a calculation of the expected accuracy of measurement for different powers and flow rates based on specified accuracies of measuring components and primary calibration at 1kW:

Measurement Data			
Power Level	1	100	kW
Flow Rate	20	60	liters/min
Heat Capacity	4.1796	4.1796	J/cm ³ /deg
Outlet T - Inlet T	0.75	24	°C
Expected Uncertainty			
Flow Rate	0.500%	0.500%	
T flow in	0.010	0.010	degC
T flow out	0.010	0.010	degC
Calibration uncertainty	1.9%		
	calibration error	additional error	
Total RSS error	3.42%	0.51%	

The above assumes that the measuring unit is indeed measuring the true water temperature rise due to the power absorbed by the beam dump. There is, however, the possibility that the chiller is not providing a constant temperature or the heated outlet water is not mixed well enough with the chilled water from the chiller to give a constant inlet water temperature. Therefore, it is recommended that the water circuit include a ballast water tank on the inlet side as shown below. If the pressure is too much for the water tank, then the pump can be placed after the water tank. For accurate measurement it is also essential that there be no trapped air bubbles in the circulating water.

When water input temperatures are changing gradually it is possible to minimize errors by defining pipe length and inner diameter in the 'Setup' screen (see below) – by defining these parameters accurately the app will be able to compensate for the temperature change.

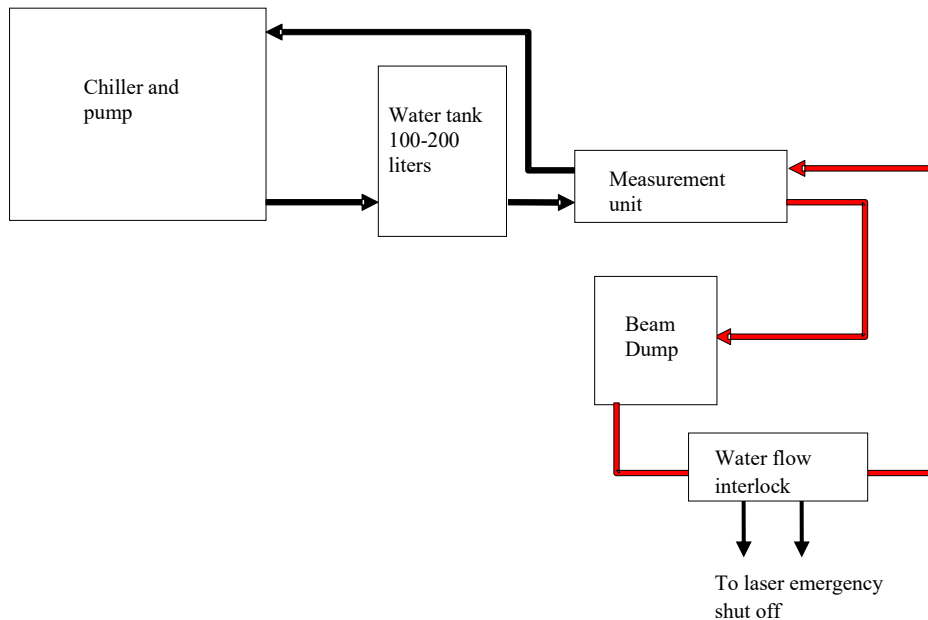

Section 2: Alignment

The beam in the 150K-W does not have to be aligned to great precision. Since the beam is so large and the device is so large, the alignment should be within about $\pm 5\text{mm}$.

If the laser can be operated at reasonably low powers $\sim 100\text{W}$ or so, a smart phone in "selfie" photo mode can look at the inside of the cavity and see the beam. First of all, the red guidance beam should be centered on the entrance opening. Then the smart phone can be used to check that the beam is falling on the center of the reflector. If the beam is centered on the reflector, then the reflected beam that falls on the walls will be a uniform ring all around.



Section 3: Operation

1. Alignment
2. Connect together the various parts of the system with the 1" OD nylon tubing. For details, see drawings in section 5. The length of the tubing should be as short as convenient so as to reduce the pressure drop on the system. In any event, the total length of tubing should not exceed the length given in the specification.

Note 1: It is important to have a safety interlock to the laser to instantly shut off the laser if the water flow drops below a preset flow rate.

Note 2: It is important that water never get on the reflecting cone. The housing is not sealed and if water is sprayed or splashed on the top of the unit, it will drip down, pick up contamination on the way from the copper coils and ruin the coating. Therefore be careful not to splash any water on the unit from the outside.
3. Set up the laser so that the beam divergence and size on the cone is as given above. Make sure the beam is perpendicular to the cone and centered on it to within the tolerance given in the specification.
4. Attach the RS232 cable between the measurement unit and the PC and attach the 12VDC power supply to the power supply socket as shown below. If you want to show the output on an Ophir smart display or PC interface, then connect the DB15 smart cable between the measuring unit and an Ophir smart meter. Note that the electronics of the measuring unit can get its power either from the wall cube power supply or the Ophir power meter or both.

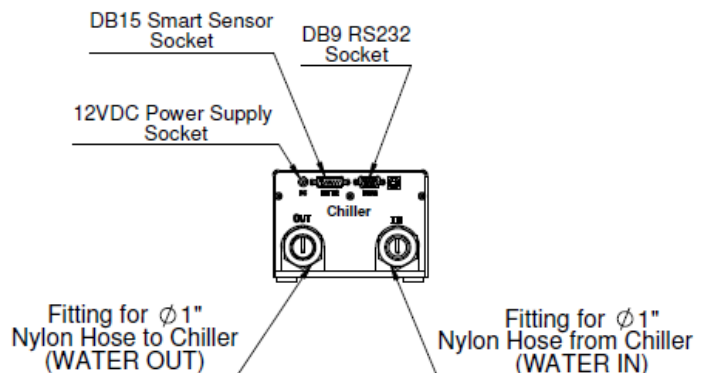

5. Measure the flow rate of the system either using RS232 commands (see section 4) or by installing 'Water Flow Meter' PC program and monitoring the screen. Turn on the water flow and set to the required value. The recommended flow rates are given below. Note that if possible, it is best to pick a particular flow rate for the entire range of powers that is going to be measured so as to minimize errors due to nonlinearity of the flow meter.

Laser Power	Flow Rate
0-20kW	20 liters/min
20-50kW	30 liters/min
50-120kW	60 liters/min
120-150kW	75 liters/min

6. Once the flow rate is set let the water run until the reading stabilizes and then set an offset when the laser is off. For low powers it is important to make a new offset every time the flow rate is changed.
7. Turn up the laser power gradually and measure the power using the RS232 commands or the PC program provided as shown below.

Section 4: Operational Safety

CAUTION Safe Carrying and Lifting

The main unit of the 150K-W Power Meter weighs approximately 50 kg and must not be lifted manually. To remove the unit from its packaging, first take off the top section of the box. Use the appropriate mechanical lifting equipment to lift the 150K-W. Use the designated lifting handles to raise the 150K-W (see drawing below).

Ensure that any lifting equipment used is rated for the 150K-W Power Meter's weight and complies with local safety regulations.

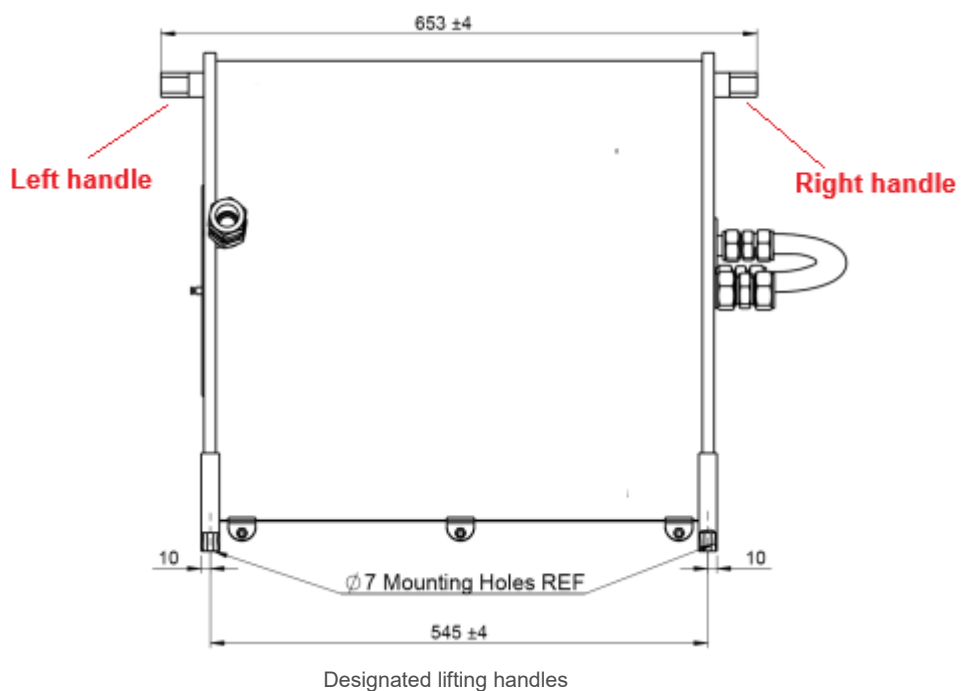

Important:

- Never lift or carry the 150K-W Power Meter by its connectors, tubing, or any attached accessories, as this may cause damage or compromise safety.
- Empty the water from the 150K-W before lifting it again.
- One side of the 150K-W is heavier than the other side, take this into account when lifting the 150K-W.

CAUTION Laser Safety – Always Wear Safety Goggles

While the 150K-W is desing as a beam trap, less then 1% of the incident power is reflected backwards through the aperture. Additionally, a much smaller amount of lighth might escape through the seams, water connector areas, etc. Therefore, when operating the 150K-W, safety goggles must be worn even if the front aperture is entirely covered, for example, by a fiber adapter.

Section 5: Operation with the PC program and RS232

1. MAIN WINDOW: After opening the PC program it will identify the attached sensor in the upper left hand side of the window: The screen displays the measured power and standard deviation at the top center. In addition the flow rate and temperatures used to calculate the power are displayed.

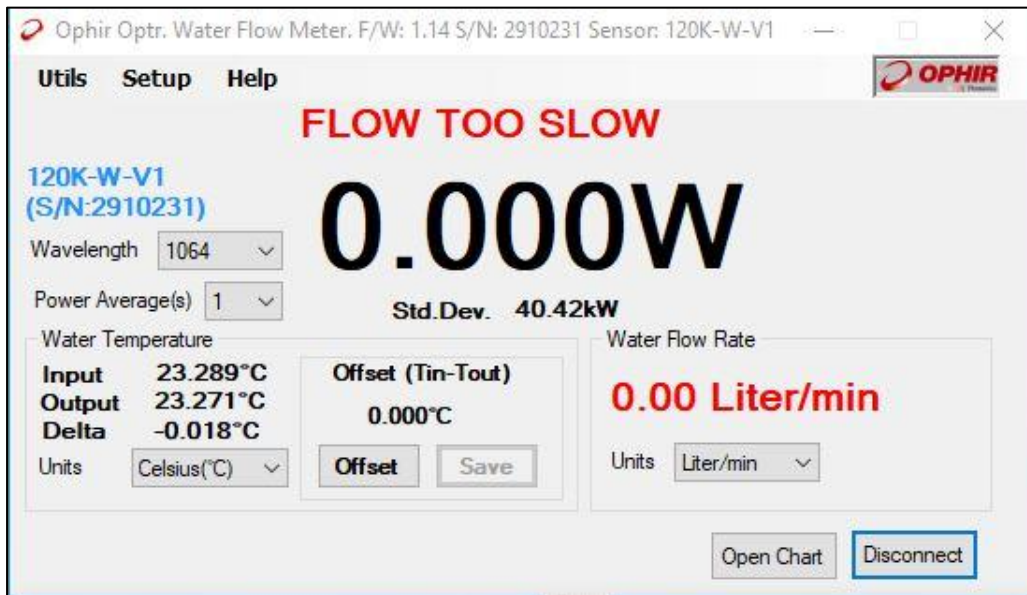

Figure 1. Main Window

As mentioned above before beginning a measurement, the water flow should be run until the Input and output temperatures stabilize -and then the offset button should be set to remove any constant temperature difference between the water at the input and output.

2. SETUP WINDOW: If a calibration factor needs to be added there are options of either a Global factor that will affect all wavelength ranges of the sensor or a wavelength range dependent factor. The factory calibration factor will be stored in the wavelength dependent calibration factor.

Before beginning operation the water flow limits should be specified in the setup window. If the water flow deviates from these critical flow limits an alarm will be shown in the main window.

In order to get the most accurate and stable measurements, it is advised to enter in the 'User Tubing Parameters' fields the length and inner diameter of the tubes used to connect the calorimetric measurement unit to the beam dump unit.

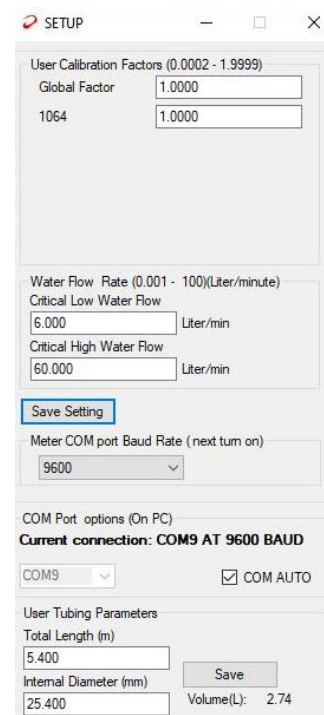

Figure 1. Setup Window

3. GRAPH WINDOW: It is possible to log and chart the data from all of the input streams over a given time period. By pressing the 'Open Chart' button in the main window will appear which gives a visual view of the power, flow rate and temperature over time. Data is logged to 'WaterFlowMeterApp' f in the 'My documents' folder.

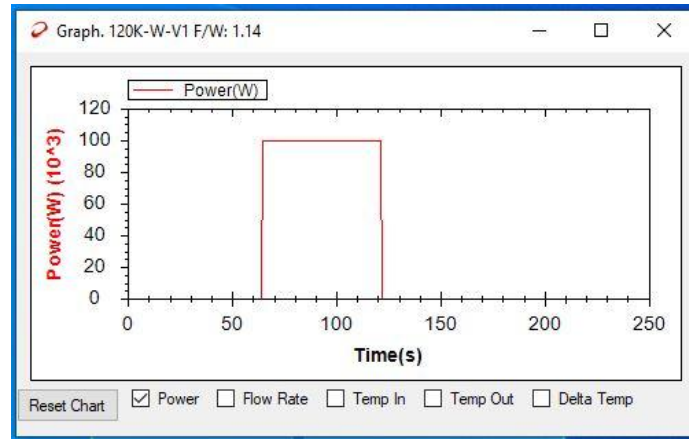

Figure 2. Chart Display

4. CALCULATOR WINDOW: The calculator allows you to test various flow parameters and temperatures in order to determine the expected outcome and set correct water flow rate.

Calculator (Simulation)

**Calculation of power according to required parameters
Without calibration factor and temperature offset**

Temperature In(°C)

Temperature Out(°C)

Water Flow (Liter/min) 95.00ml/s

Power(W) 4765.6

Delta (°C) 11.987

Specific Gravity(g/ml) 0.998

$P = dT * C * G * S$

dT-Temperature difference : (°C)
G -Specific gravity:(g/ml)
S-Water speed :(ml/s)
C-Heat capacity : 4.193 [J/(g·K)] +/-0.3% for 10C-90C

Figure 4. Calculator Window

RS232 Commands:

4.1 General Information:

All commands are initiated by PC; sensor responds to them ONLY AFTER RECEIVING THE FINAL [CR] symbol

All communications with PC are in ASCII symbols – not binary values

All commands from PC begin with '\$' symbol

All commands should end with Carriage Return symbol (#13, 0xD, '[CR]', '\r' in "C" language). Adding Line Feed (#10, 0xA, [LF], '\n') is optional.

All commands are defined by two ASCII characters that can be lower or upper case

All REPLIES begin with a '*' symbol (for 'OK') or a '?' (for an error) and end with [CR][LF]

4.2 Commands:

Test communications ("Ping"): \$HP[CR][LF] -> *[CR][LF] {Checks communications in Winpack}

Send Version: \$VE[CR][LF] -> *WM1.23[CR][LF] {Returns software version}

Send Power: \$SP[CR][LF] -> *1.23456E5[CR][LF] {Returns power in Watts in E format, up to once a second}

Send Temperature: \$ST[CR][LF] -> *24.567 36.789[CR][LF] {Returns temperature of water entering and leaving sensor in Degrees Celsius, once per second}

Send Water Flow: \$FV[CR][LF] -> *10.657[CR][LF] {Returns water flow rate in liters/minute, once per second}

Continuous Send: \$CS 0[CR][LF] -> 0 | 1 | 2[CR][LF] {Queries present continuous send mode, 0, 1, 2, 3, default at power up is 1}

\$CS 1[CR][LF] -> *[CR][LF] {Switches OFF continuous send mode}

\$CS 2[CR][LF] -> *[CR][LF] {Switches ON continuous send mode, Power Only Mode. Sensor then begins sending power data once a second for example:

*1.23456E5[CR][LF]

*1.24456E5[CR][LF]

*1.25456E5[CR][LF]

*1.24456E5[CR][LF] }

\$CS 3[CR][LF] -> *[CR][LF] {Switches ON continuous send mode, FULL Mode. Sensor then begins sending temperature, water flow and power data (in that order) once a second, for example:

*24.567 36.789 10.657 1.23456E5[CR][LF]

*24.567 36.879 10.657 1.27456E5[CR][LF]

*24.567 36.789 10.657 1.23456E5[CR][LF]

Note: when in continuous send mode, only the \$CS 1 command will switch OFF continuous send mode. In this mode, the PC s/w should poll receives continuously after sending the \$CS 1 command, to make sure no more data has been sent by the sensor, before sending another command.

Otherwise the response to the new command will be confused with the data being continuously sent by the sensor.

Global Calibration factor: \$CQ

Queries/Sets Global Calibration Factor.

Query: returns a float number

Set: Uses an integer value (10000 x calibration factor)

\$CQ or \$CQ 0 – queries present calibration factor

\$CQ 0[CR][LF] -> ***1.1121** 1.0000 1.0000 2.3321E-09[CR][LF] (present Calibration Factor is 1.1121, *the other parameters are not relevant*)

\$CQ 1 **12345**[CR][LF] -> ***1.2345** 1.0000 1.0000 2.1009E-09[CR][LF] (*sets new Calibration Factor to 1.2345*)

Send \$HC to save new parameters into EEROM

Set Tubing Parameters: \$PM:

\$PM has 2 arguments: Length of Tubing (in mm) and inner diameter of Tubing (in um).

Set the parameters using integers:

\$PM 2345 2111[CR][LF] -> * 2345 2111[CR][LF] (sets Length to 2.345m, Diameter to 2.111mm)

Query:

\$PM[CR][LF] -> * 2345 2111[CR][LF]

Set/Get Temperature offset \$OT:

Sets Temperature Offset (Tout-Tin) in "milli °C" (°C x 1000). This is the difference in temperature reading between the input and output without a laser, with only water flowing. Saved in EEROM using \$HC command.

Parameters:

No parameter or 0: Get present temperature offset

2: Set current delta temperature as new offset (automatically measured by sensor)

Query:

\$OT[CR][LF] -> *1234 [CR][LF] (meaning 1.234°C)

\$OT[CR][LF] *-432[CR][LF] *-432 (meaning -0.432°C)

\$OT 2[CR][LF] -> *1234[CR][LF] (measures new value and returns the measured value)

Flow Limits \$FL:

Queries or sets lower and upper flow rate limits in Liters per minute for warning levels in GUI.

Use \$HC command to save.

Set:

\$FL 1 10.000 : sets MIN value to 10.000

\$FL 2 30.000 : sets MAX value to 30.000

Query:

No parameter: returns values Min, Max in Liter/min with resolution of 1ml/min

\$FL[CR][LF] -> 10.000 30.000 [CR][LF]

Section 6: Drawings

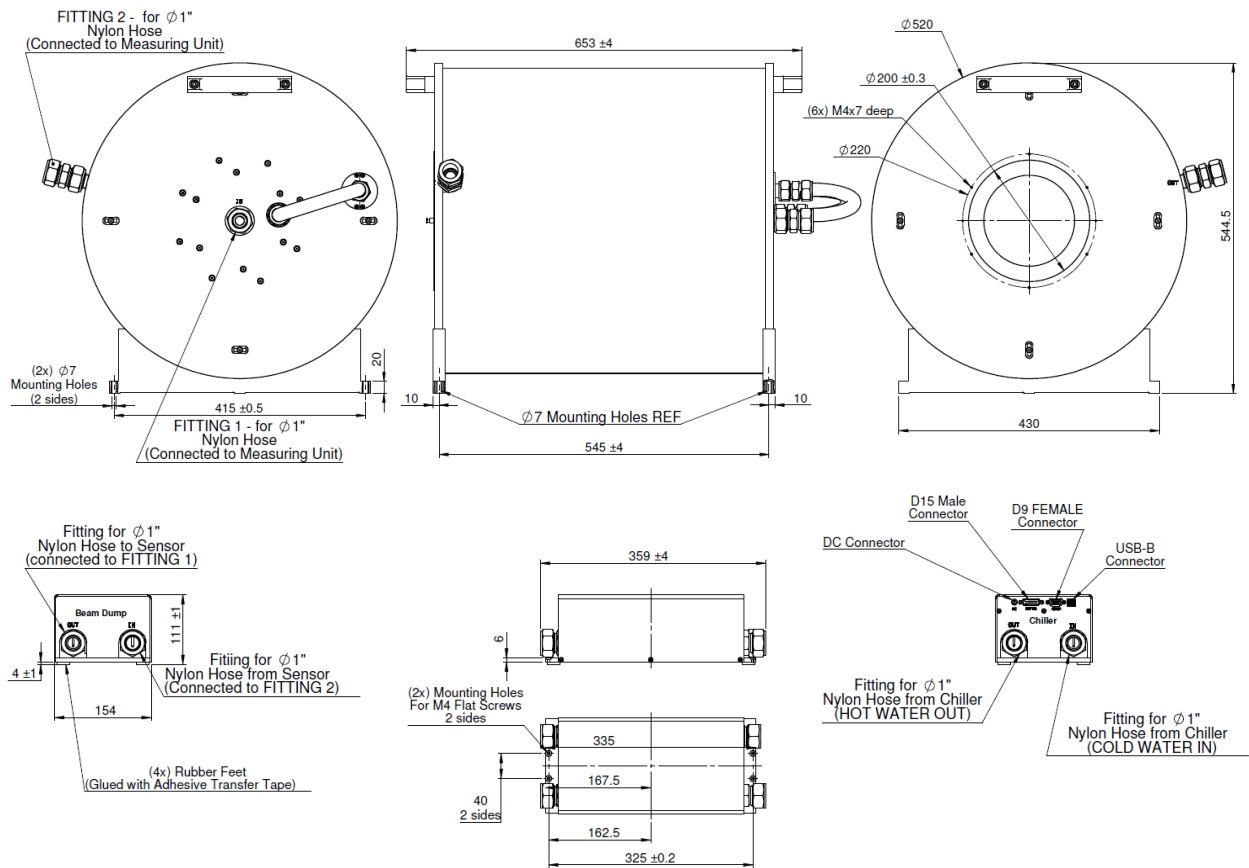

Copyright © 2020-2026 by MKS Inc.

All rights reserved. No part of this work may be reproduced or transmitted in any form or by any means, electronic or mechanical, including photocopying and recording, or by any information storage or retrieval system, except as may be expressly permitted in writing by MKS Inc.

Document No sp1 User Notes for 150K-W 7Z07152 Rev 2 02 Feb 2026

For latest version, please visit our website: www.ophiropt.com